

Optoelectronic devices

This worksheet and all related files are licensed under the Creative Commons Attribution License, version 1.0. To view a copy of this license, visit <http://creativecommons.org/licenses/by/1.0/>, or send a letter to Creative Commons, 559 Nathan Abbott Way, Stanford, California 94305, USA. The terms and conditions of this license allow for free copying, distribution, and/or modification of all licensed works by the general public.

Resources and methods for learning about these subjects (list a few here, in preparation for your research):

Questions

Question 1

The characteristically colored glow from a gas-discharge electric light is the result of energy emitted by electrons in the gas atoms as they fall from high-level "excited" states back to their natural ("ground") states. As a general rule of electron behavior, they must absorb energy from an external source to leap into a higher level, and they release that energy upon returning to their original level.

Given the existence of this phenomenon, what do you suspect might be occurring inside a PN junction as it conducts an electric current?

[file 00911](#)

Question 2

What determines the color of an LED?

[file 01028](#)

Question 3

What is the typical forward voltage drop for a light-emitting diode? What is the typical forward current for an LED?

[file 01027](#)

Question 4

Explain the operating principle of a *photovoltaic cell*, otherwise known as a "solar cell." What happens within these devices to convert sunlight directly into electricity?

[file 01029](#)

Question 5

What happens when external light strikes the PN junction of an LED? Design and operate an experiment to verify your hypothesis.

[file 01030](#)

Question 6

Photodiodes may be operated in either "photovoltaic" mode or in "photoconductive" mode. Describe the difference between these two modes, drawing schematic diagrams showing how a photodiode would be used in each mode.

[file 01031](#)

Question 7

In this circuit, the electric motor is supposed to turn on whenever the cadmium sulfide photocell is darkened:

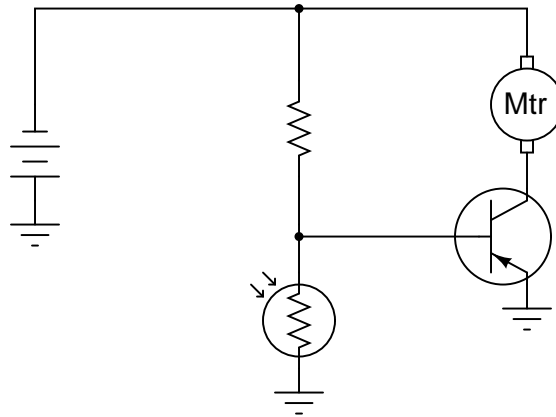

Unfortunately, though, the motor refuses to turn on no matter how little light strikes the photocell. In an attempt to troubleshoot the circuit, a technician measures voltage between the collector and emitter terminals of the transistor with the photocell covered by a piece of dark tape, and measures full battery voltage. The technician also measures voltage between the collector and base terminals of the transistor, and measures full battery voltage. At that point, the technician gives up and hands the problem to you.

Based on this information, what do you suspect is faulty in this circuit, and how might you determine the exact location of the fault? Also, identify what you know to be *not* faulted in the circuit, based on the information given here.

[file 00501](#)

Question 8

Describe the function of a *phototransistor*. What typical applications do phototransistors have in circuits? What is the schematic symbol for a phototransistor, and how is it properly biased?

[file 01032](#)

Question 9

Photodiodes, phototransistors, and light-emitting diodes all play important roles in *optical communications networks*, where digital (on/off) signals are communicated over long distances as pulses of light energy rather than voltage or current.

Why are LEDs greatly preferred over other electro-optical devices such as incandescent lamps or gas-discharge bulbs? What can an LED do that a small electric lamp cannot?

[file 01033](#)

Don't just sit there! Build something!!

Learning to mathematically analyze circuits requires much study and practice. Typically, students practice by working through lots of sample problems and checking their answers against those provided by the textbook or the instructor. While this is good, there is a much better way.

You will learn much more by actually *building and analyzing real circuits*, letting your test equipment provide the "answers" instead of a book or another person. For successful circuit-building exercises, follow these steps:

1. Carefully measure and record all component values prior to circuit construction, choosing resistor values high enough to make damage to any active components unlikely.
2. Draw the schematic diagram for the circuit to be analyzed.
3. Carefully build this circuit on a breadboard or other convenient medium.
4. Check the accuracy of the circuit's construction, following each wire to each connection point, and verifying these elements one-by-one on the diagram.
5. Mathematically analyze the circuit, solving for all voltage and current values.
6. Carefully measure all voltages and currents, to verify the accuracy of your analysis.
7. If there are any substantial errors (greater than a few percent), carefully check your circuit's construction against the diagram, then carefully re-calculate the values and re-measure.

When students are first learning about semiconductor devices, and are most likely to damage them by making improper connections in their circuits, I recommend they experiment with large, high-wattage components (1N4001 rectifying diodes, TO-220 or TO-3 case power transistors, etc.), and using dry-cell battery power sources rather than a benchtop power supply. This decreases the likelihood of component damage.

As usual, avoid very high and very low resistor values, to avoid measurement errors caused by meter "loading" (on the high end) and to avoid transistor burnout (on the low end). I recommend resistors between 1 k Ω and 100 k Ω .

One way you can save time and reduce the possibility of error is to begin with a very simple circuit and incrementally add components to increase its complexity after each analysis, rather than building a whole new circuit for each practice problem. Another time-saving technique is to re-use the same components in a variety of different circuit configurations. This way, you won't have to measure any component's value more than once.

[file 00505](#)

Answers

Answer 1

PN junctions emit energy of a characteristic wavelength when conducting current. For some types of PN junctions, the wavelengths are within the visible range of light.

Follow-up question: what practical application can you think of for this phenomenon?

Answer 2

The type of semiconductor materials used to make the PN junction determine the color of light emitted.

Challenge question: describe the relationship between LED color and typical forward voltage, in terms of photon frequency, energy, and semiconductor band gap.

Answer 3

LED forward current is 20 mA. Forward voltage varies with color.

Answer 4

The energy of photons (light "particles") striking a PN semiconductor junction creates electron-hole pairs, which then move in the direction that the depletion region's electric field pushes them.

Challenge question: of what significance is the *band gap* of the PN junction to the efficiency of the cell?

Answer 5

Did you really think I would reveal the answer to this question?

Answer 6

Photoconductive mode

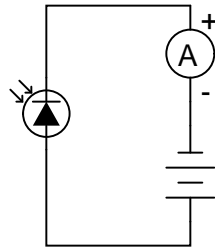

Photovoltaic mode

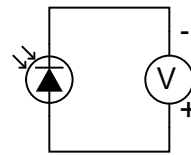

Answer 7

The battery, and its connections to the rest of the circuit, are in good condition. Also, we know that the motor is not failed open. In all likelihood, the transistor is not being "told" to turn on.

Answer 8

Phototransistors are used as light sensors, and also as electrically isolated switching elements when illuminated by LEDs.

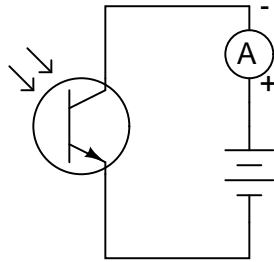

Answer 9

Semiconductor-based light emitting devices are capable of turning on and off much, much faster than incandescent or gas-discharge devices.

Answer 10

Let the electrons themselves give you the answers to your own "practice problems"!

Notes

Notes 1

The practical application of this phenomenon should be obvious, and it is very commonplace in modern electronic equipment. Discuss with your students the energy-efficiency of this light emission as compared to an incandescent lamp.

Notes 2

Ask your students to identify some common LED materials and colors, and of course cite their sources as they do. The challenge question may be readily answered through experimentation with different LED colors, although a physics-based explanation will take some additional research. This kind of experiment is very easy to conduct in class, together.

If time permits, you might wish to mention Albert Einstein's contribution to this aspect of physics: his formulation for the energy carried by a photon (a *quantum*) of light:

$$E = hf$$

Where,

E = Energy carried by photon, in Joules

h = Planck's constant, 6.63×10^{-34} J·s

f = Frequency of light, in Hertz ($\frac{1}{s}$)

Typical frequencies for visible light colors range from 4×10^{14} Hz for red, to 7.5×10^{14} Hz for violet.

Notes 3

Be sure to ask students where they obtained their information, and what some of the forward voltage drops are for different color LEDs.

Notes 4

There is quite a bit of detail that could be added to the account given in the answer. Ask your students to supply some of this detail! There are many resources for learning how photovoltaic cells work, so your students should have no trouble finding the information on their own.

Notes 5

This makes an excellent in-class experiment, and demonstrates a useful property of LEDs that not many people know about.

Notes 6

Ask your students whether a regular LED could be used as a photodiode in each of these modes. How would they set up an experiment to test an LED's ability to act as a photodiode in each mode?

Notes 7

It is just as important for your students to be able to identify what is *not* faulted in a system as it is for them to be able to identify what is faulted. Replacing components that are not faulted is expensive and wasteful!

An essential part of answering this question is what the photocell does when light strikes it. Obviously, it undergoes a change in electrical resistance, but which way? This is something your students will have to determine before they can successfully troubleshoot the system. If they do not understand what the system is *supposed* to do, they will be helpless in interpreting what it is presently doing.

Notes 8

Ask your students what point there would be in illuminating a phototransistor with an LED. Why not just dispense with the LED and just use a normal transistor to allow one electrical signal to control another?

Notes 9

In digital communications networks, speed is an essential quality. Ask your students why this is so, and by association, why semiconductor-based light sources are almost exclusively used in optical networks.

Notes 10

It has been my experience that students require much practice with circuit analysis to become proficient. To this end, instructors usually provide their students with lots of practice problems to work through, and provide answers for students to check their work against. While this approach makes students proficient in circuit theory, it fails to fully educate them.

Students don't just need mathematical practice. They also need real, hands-on practice building circuits and using test equipment. So, I suggest the following alternative approach: students should *build* their own "practice problems" with real components, and try to mathematically predict the various voltage and current values. This way, the mathematical theory "comes alive," and students gain practical proficiency they wouldn't gain merely by solving equations.

Another reason for following this method of practice is to teach students *scientific method*: the process of testing a hypothesis (in this case, mathematical predictions) by performing a real experiment. Students will also develop real troubleshooting skills as they occasionally make circuit construction errors.

Spend a few moments of time with your class to review some of the "rules" for building circuits before they begin. Discuss these issues with your students in the same Socratic manner you would normally discuss the worksheet questions, rather than simply telling them what they should and should not do. I never cease to be amazed at how poorly students grasp instructions when presented in a typical lecture (instructor monologue) format!

A note to those instructors who may complain about the "wasted" time required to have students build real circuits instead of just mathematically analyzing theoretical circuits:

What is the purpose of students taking your course?

If your students will be working with real circuits, then they should learn on real circuits whenever possible. If your goal is to educate theoretical physicists, then stick with abstract analysis, by all means! But most of us plan for our students to do something in the real world with the education we give them. The "wasted" time spent building real circuits will pay huge dividends when it comes time for them to apply their knowledge to practical problems.

Furthermore, having students build their own practice problems teaches them how to perform *primary research*, thus empowering them to continue their electrical/electronics education autonomously.

In most sciences, realistic experiments are much more difficult and expensive to set up than electrical circuits. Nuclear physics, biology, geology, and chemistry professors would just love to be able to have their students apply advanced mathematics to real experiments posing no safety hazard and costing less than a textbook. They can't, but you can. Exploit the convenience inherent to your science, and *get those students of yours practicing their math on lots of real circuits!*