

Design Project: intercom system

This worksheet and all related files are licensed under the Creative Commons Attribution License, version 1.0. To view a copy of this license, visit <http://creativecommons.org/licenses/by/1.0/>, or send a letter to Creative Commons, 559 Nathan Abbott Way, Stanford, California 94305, USA. The terms and conditions of this license allow for free copying, distribution, and/or modification of all licensed works by the general public.

Intercom systems allow two people to talk across long distances over a pair of speakers, each speaker alternately serving as a microphone as well. The following schematic diagram shows a suggested intercom circuit that works well using standard dynamic (electromagnetic) speakers, using a double-pole, double-throw switch to control the direction of communication:

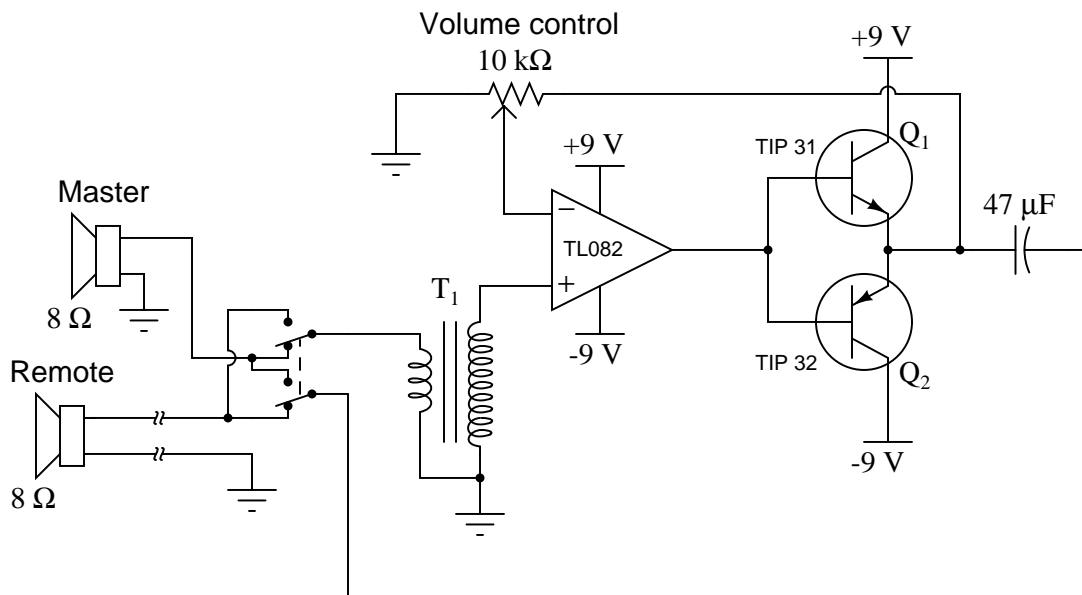

The complete absence of biasing on the power transistors keeps them well away from class AB operation where they would dissipate substantial heat and consume more quiescent power, yet the audio quality is fine for speech. The transformer (T_1) is just a step-down power unit taken from a wall-plug AC/DC power supply or the power supply from a small electronic appliance such as a clock radio. A ratio of about 120 to 6 seems to work well. This helps match the speaker's low impedance to the opamp's high impedance, while maintaining low impedance on the "microphone" side for maximum rejection of electrical interference.

I have used power supply voltages of 9 volts (+V = +4.5 volts ; -V = -4.5 volts), 12 volts (+V = +6 volts; -V = -6 volts), and 18 volts (+V = +9 volts; -V = -9 volts), all with good success. Of course, you are not restricted to using this exact design – feel free to modify it!

Deadlines (set by instructor):

- Project design completed:
- Components purchased:
- Working prototype:
- Finished system:
- Full documentation:

Questions

Question 1

After experimenting some with this intercom circuit, you will find that there is a point on the volume control below which so little sound is reproduced that it is almost useless, and a point above which there is substantial distortion. Explain how you could place "stops" to limit the volume control range so that the user could not adjust past these points, making the volume control more useful.

[file 02747](#)

Question 2

Design a passive circuit that will create a "split" (+V/-V) power supply from a single voltage source:

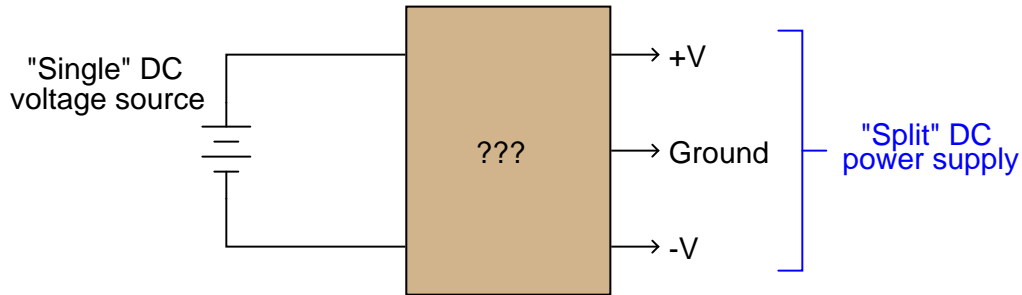

[file 02748](#)

Question 3

Suppose a student builds this circuit and notices that it spontaneously breaks into oscillations, whether or not the "microphone" speaker is picking up any sound. Identify some possible causes of oscillation in a circuit like this, as well as possible fixes.

[file 02784](#)

Answer 1

Place "stop" resistors before and after the potentiometer, sized appropriately to limit the minimum and maximum volumes to whatever levels are desired:

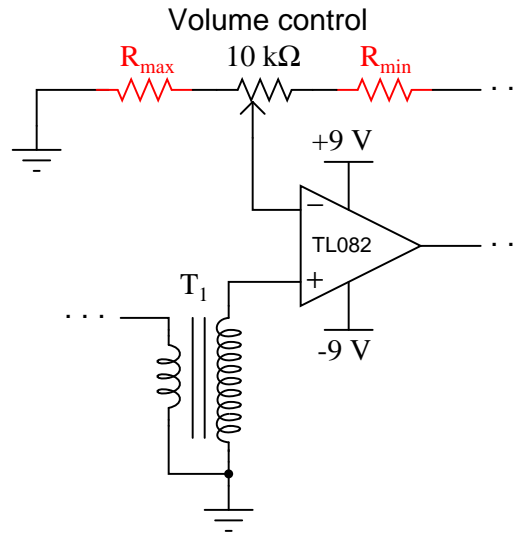

Answer 2

For low-current applications, the following resistor/capacitor network works remarkably well:

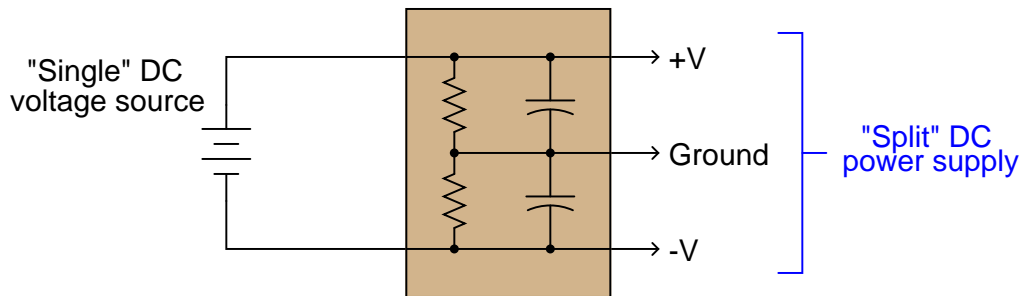

Follow-up question: what design constraints will dictate the sizes of the resistors and capacitors?

Answer 3

At root, the cause of oscillation in an amplifier circuit is some form of positive (regenerative) feedback. Possible causes include:

- Insufficient power supply decoupling (*add a large capacitor across the power supply terminals of the opamp.*)
- Stray capacitive coupling between input and output wiring (*re-route wires, keeping input and output wiring well separated.*)
- Amplifier gain too high (*add limiting resistor(s) to the opamp's feedback to prevent the gain adjustment from being set too high.*)
- Transformer phasing (*reverse one winding of the transformer with respect to the other winding.*)

Notes

Notes 1

This technique is frequently used to "bound" the range of a potentiometer within a pair of desired limits. For a circuit such as this, the only way to really determine where the upper and lower limits are is by experimenting.

Notes 2

This simple filtered voltage divider circuit works well when the current draws are low, or at least very close to being equal, on the +V and -V load rails. It does not work so well for highly asymmetrical loads, or where low quiescent current draw is important (low-power battery circuits, for example). In applications requiring better +V/-V voltage stability, an opamp "follower" circuit is recommended after the voltage divider.

Notes 3

Unwanted oscillations in amplifier circuitry is a very real problem many electronics technicians and engineers alike must face. There is often no single correct solution to the problem, given the multiple avenues through which regenerative feedback may take place in a circuit.